



SIEMECA™

Electronic Heat and Cooling Meters

WFR...
WFN...

Electronic, mains-independent meters to acquire the heat and cooling energy consumption in autonomous heating, cooling and domestic hot water plants. Storage and display of the cumulated consumption values on a selectable set day.

Available as single-jet meters in «combined» all-in-one or split version

Nominal flow rates of single-jet meters 0.6 m³/h, 1.5 m³/h or 2.5 m³/h.

The electronic Siemeca™ heat and cooling meter is a component of the Siemeca™ AMR, the Siemeca™ Radio Metering and the Siemeca™ M-Bus Metering Systems.

Use

The electronic Siemeca heat and cooling meters are used for measuring heat and cooling energy. Their major field of use are central heating and cooling plants, where heat and cooling energy are delivered individually to several consumers.

Plants of this type are used in buildings such as

- multi-family houses
- office and administrative buildings

Typical users are:

- Private building owners
- Property associations
- Building maintenance companies
- Housing estate agents

Functions

- Ascertains heat and cooling energy consumption by measuring flow and temperature difference
- Aggregates consumption values
- Records cumulative consumption values on reference date
- Displays consumption values
- Displays main operating data
- Self-monitoring with error display
- Data transmission by M-bus and radio

Type summary

List of heat and cooling meters

M-Bus-Versions

Nominal flow rate q_p	Mounting length	Temperature sensors			Communication	Type reference**
		Cable length	Immersion	Return temp. sensor		
0.6 m ³ /h	110 mm	1.5 m	directly	integrated	via M-bus*	WFN21.B111
1.5 m ³ /h	110 mm	1.5 m	directly	integrated	via M-bus*	WFN21.D111
2.5 m ³ /h	130 mm	1.5 m	directly	integrated	via M-bus*	WFN21.E131
0.6 m ³ /h	110 mm	2.5 m	directly	integrated	via M-bus*	WFN21.B112
1.5 m ³ /h	110 mm	2.5 m	directly	integrated	via M-bus*	WFN21.D112
2.5 m ³ /h	130 mm	2.5 m	directly	integrated	via M-bus*	WFN21.E132
1.5 m ³ /h	80 mm	1.5 m	directly	not integrated	via M-bus*	WFR21.D081
1.5 m ³ /h	80 mm	2.5 m	directly	not integrated	via M-bus*	WFR21.D082
1.5 m ³ /h	110 mm	1.5 m	indirectly	integrated	via M-bus*	WFN21.D115
2.5 m ³ /h	130 mm	1.5 m	indirectly	integrated	via M-bus*	WFN21.E135
1.5 m ³ /h	110 mm	2.5 m	indirectly	integrated	via M-bus*	WFN21.D116
2.5 m ³ /h	130 mm	2.5 m	indirectly	integrated	via M-bus*	WFN21.E136

* Prepared for communication via M-bus

** Short-form

Radio 433MHz-Versions

Nominal flow rate q_p	Mounting length	Temperature sensors			Communication	Type reference**
		Cable length	Immersion	Return temp. sensor		
0.6 m ³ /h	110 mm	1.5 m	directly	integrated	via radio 433 MHz	WFN22.B111
1.5 m ³ /h	110 mm	1.5 m	directly	integrated	via radio 433 MHz	WFN22.D111
2.5 m ³ /h	130 mm	1.5 m	directly	integrated	via radio 433 MHz	WFN22.E131
0.6 m ³ /h	110 mm	2.5 m	directly	integrated	via radio 433 MHz	WFN22.B112
1.5 m ³ /h	110 mm	2.5 m	directly	integrated	via radio 433 MHz	WFN22.D112
2.5 m ³ /h	130 mm	2.5 m	directly	integrated	via radio 433 MHz	WFN22.E132
1.5 m ³ /h	80 mm	1.5 m	directly	not integrated	via radio 433 MHz	WFR22.D081
1.5 m ³ /h	80 mm	2.5 m	directly	not integrated	via radio 433 MHz	WFR22.D082
1.5 m ³ /h	110 mm	1.5 m	indirectly	integrated	via radio 433 MHz	WFN22.D115
2.5 m ³ /h	130 mm	1.5 m	indirectly	integrated	via radio 433 MHz	WFN22.E135
1.5 m ³ /h	110 mm	2.5 m	indirectly	integrated	via radio 433 MHz	WFN22.D116
2.5 m ³ /h	130 mm	2.5 m	indirectly	integrated	via radio 433 MHz	WFN22.E136

** Short-form

Pulse Output-Versions

Nominal flow rate q_p	Mounting length	Temperature sensors			Communication	Type reference**
		Cable length	Immersion	Return temp. sensor		
0.6 m ³ /h	110 mm	1.5 m	directly	integrated	Pulse Output	WFN24.B111
1.5 m ³ /h	110 mm	1.5 m	directly	integrated	Pulse Output	WFN24.D111
2.5 m ³ /h	130 mm	1.5 m	directly	integrated	Pulse Output	WFN24.E131
0.6 m ³ /h	110 mm	2.5 m	directly	integrated	Pulse Output	WFN24.B112
1.5 m ³ /h	110 mm	2.5 m	directly	integrated	Pulse Output	WFN24.D112
2.5 m ³ /h	130 mm	2.5 m	directly	integrated	Pulse Output	WFN24.E132
1.5 m ³ /h	80 mm	1.5 m	directly	not integrated	Pulse Output	WFR24.D081
1.5 m ³ /h	80 mm	2.5 m	directly	not integrated	Pulse Output	WFR24.D082
1.5 m ³ /h	110 mm	1.5 m	indirectly	integrated	Pulse Output	WFN24.D115
2.5 m ³ /h	130 mm	1.5 m	indirectly	integrated	Pulse Output	WFN24.E135
1.5 m ³ /h	110 mm	2.5 m	indirectly	integrated	Pulse Output	WFN24.D116
2.5 m ³ /h	130 mm	2.5 m	indirectly	integrated	Pulse Output	WFN24.E136

** Short-form

Radio 868 MHz-Versions

Nominal flow rate q_p	Mounting length	Temperature sensors			Communication	Type reference**
		Cable length	Immersion	Return temp. sensor		
0.6 m ³ /h	110 mm	1.5 m	directly	integrated	via radio 868 MHz	WFN26.B111
1.5 m ³ /h	110 mm	1.5 m	directly	integrated	via radio 868 MHz	WFN26.D111
2.5 m ³ /h	130 mm	1.5 m	directly	integrated	via radio 868 MHz	WFN26.E131
0.6 m ³ /h	110 mm	2.5 m	directly	integrated	via radio 868 MHz	WFN26.B112
1.5 m ³ /h	110 mm	2.5 m	directly	integrated	via radio 868 MHz	WFN26.D112
2.5 m ³ /h	130 mm	2.5 m	directly	integrated	via radio 868 MHz	WFN26.E132
1.5 m ³ /h	80 mm	1.5 m	directly	not integrated	via radio 868 MHz	WFR26.D081
1.5 m ³ /h	80 mm	2.5 m	directly	not integrated	via radio 868 MHz	WFR26.D082
1.5 m ³ /h	110 mm	1.5 m	indirectly	integrated	via radio 868 MHz	WFR26.D115
2.5 m ³ /h	130 mm	1.5 m	indirectly	integrated	via radio 868 MHz	WFR26.E135
1.5 m ³ /h	110 mm	2.5 m	indirectly	integrated	via radio 868 MHz	WFR26.D116
2.5 m ³ /h	130 mm	2.5 m	indirectly	integrated	via radio 868 MHz	WFR26.E136

** Short-form

Scope of delivery of heat and cooling meters

Item	Temperature sensors, length and immersion					Packing
	80 mm	110 mm, directly	110 mm, indirectly	130 mm, directly	130 mm, indirectly	
Flow measuring section	•	•	•	•	•	Box
Electronic unit	•	•	•	•	•	Box
Temperature sensor with fitting	•	•	•	•	•	Box
Bracket	•	•	•	•	•	Box
Protective cap	2×	2×	2×	2×	2×	Box
Mounting instructions	•	•	•	•	•	Box
Commissioning and operating instructions	•	•	•	•	•	Box
Flat seal	2×	2×	2×	2×	2×	Bag 1
Sealing wire	3×	2×	2×	2×	2×	Bag 1
Self-lock seal	3×	2×	2×	2×	2×	Bag 1
(Adhesive seal)	•	•	•	•	•	Bag 1
Fischer dowel S6	2×	2×	2×	2×	2×	Bag 2
Screws C 4.2×25	2×	2×	2×	2×	2×	Bag 2

List of mounting kits

<i>Scope of delivery, description</i>	<i>Type reference</i>
For 80 mm mounting length, both sensors directly immersed, flow temp. sensor in ball valve	WFZ.E80
For 80 mm mounting length, return temp. sensors directly immersed, flow temp. sensor in ball valve	WFZ.E80G3
For 110 mm mounting length, return temp. sensors directly immersed, flow temp. sensor in ball valve	WFZ.E110-I
For 110 mm mounting length, return temp. sensor indirectly immersed, flow temp. protection pocket	WFZ.E110-IT
For 110 mm mounting length, return temp. sensor directly immersed, flow temp. ball valve	WFZ.E110G3-I
For 110 mm mounting length, return temp. sensor indirectly immersed, flow temp. protection pocket	WFZ.E110G3-IT
For 130 mm mounting length, return temp. sensor directly immersed, flow temp. ball valve	WFZ.E130-I
For 130 mm mounting length, return temp. sensor indirectly immersed, flow temp. protection pocket	WFZ.E130-IT
For 130 mm mounting length, return temp. sensor directly immersed, flow temp. ball valve	WFZ.E130G1-I
For 130 mm mounting length, return temp. sensor indirectly immersed, flow temp. protection pocket	WFZ.E130G1-IT

Scope of delivery of mounting kits

<i>Accessory</i>	<i>WFZ-</i>									
	<i>E80</i>	<i>E80G3</i>	<i>E110-I</i>	<i>E110-IT</i>	<i>E110G3-I</i>	<i>E110G3-IT</i>	<i>E130-I</i>	<i>E130-IT</i>	<i>E130G1-I</i>	<i>E130G1-IT</i>
Spacer	•	•	•	•	•	•	•	•	•	•
Ball valve, internally threaded ½", for use in return pipe, cap nut * ¾", with thread for sensor, flat seal ¾"	•	•								
Ball valve, internally threaded ½", for use in return pipe, cap nut* ¾", flat seal ¾"	•	•	2×	2×	2×	2×				
Ball valve, internally threaded ¾", for use in return pipe, fitting ¾" with cap nut 1", flat seal 1"							2×	2×	2×	2×
Ball valve, internally threaded ½", for use in flow pipe, with thread for sensor	•		•							
Ball valve, internally threaded ¾", for use in flow pipe, with thread for sensor		•			•		•			
Ball valve, internally threaded 1", for use in flow pipe, with thread for sensor									•	
T-piece, internally threaded ½", for use in flow pipe				•						
T-piece, internally threaded ¾", for use in flow pipe						•		•		
T-piece, internally threaded 1", for use in flow pipe										•
Protection pocket M10x1				•		•		•		•

* Cap nut integrated in ball valve (cannot be removed)

List of accessories

<i>Accessory</i>	<i>Description, scope of delivery</i>	<i>Type reference</i>
Spacer	For mounting length 80 mm (¾" male)	WFZ.R80
Spacer	For mounting length 110 mm (¾" male))	WFZ.R110
Spacer	For mounting length 130 mm (1" male)	WFZ.R130
Ball valve	Connecting thread ½", with thread for sensor	WFZ.K15

<i>Accessory</i>	<i>Description, scope of delivery</i>	<i>Type reference</i>
Ball valve	Connecting thread ¾", with thread for sensor	WFZ.K18
Ball valve	Connecting thread 1", with thread for sensor	WFZ.K22
T-piece	Internally threaded ½", with protection pocket M10x1	WFZ.T16
T-piece	Internally threaded ¾", with protection pocket M10x1	WFZ.T19
T-piece	Internally threaded 1", with protection pocket M10x1	WFZ.T22
Covering plate IV	Chromium-plated	WFZ.B4
M-bus connection kit	1 plug with cable (1 m long; 1 adhesive label)	WFZ.MBUSSET

Functions

- Acquisition of heat and cooling energy consumption based on the measurements of flow rate and temperature differential
- Cumulation of the consumption values
- Storage of the cumulated consumption values on the set day
- Display of the consumption values
- Display of the key operational data
- Self-supervision, with fault indication
- Data transmission via M-bus or radio

Ordering

When ordering, please give type reference according to «Type summary».

The electronic Siemeca heat and cooling meter comes standard with an M-bus output. If the heat and cooling meter is connected to a SYNERGYR M-Bus Metering System, the M-bus connection kit is required. For the pulse output version the M-bus connection kit is also required.

If a set day other than 31 December is required, the desired month is to be added to the type reference when ordering (normally, the last day of the month is the set day).

Ordering example for a heat and cooling meter, 130 mm mounting length, set day 30 April: **WFN21.E131, set day: April**

Technical design

Measurement principle

The meter operates based on the single-jet measurement principle where the water jet hits the impeller tangentially. The impeller's speed is sensed electronically without producing a magnetic field.

The temperatures in the flow and return pipes are measured with immersion type platinum sensing elements (Pt500).

Acquisition of heat consumption

The heat and cooling meter is designed for mounting in the return pipe.

The electronic unit measures the flow continuously and the flow and return temperatures at least once in four minutes. A microprocessor in the electronic unit determines the temperature differential which the microprocessor uses, along with the mean flow rate and the heat coefficient, to calculate the amount of heat consumed (or, with the cooling coefficient, to calculate the amount of cooling energy consumed).

Storage of consumption values

The heat and cooling energy consumption values are continuously cumulated. At 23.59 hours of the next set day, the actual meter reading will be stored.

The set day is factory-set, the standard setting being 31 December (also refer to «Ordering»).

At the time the annual consumption values are stored, the meter calculates a verification code. Tenants who make their own reading need to give this code to the billing centre, along with the set day reading. This enables the billing centre to verify the reading. The stored set day value will be retained for one year.

Display

The meter has three display levels which show the following values and variables:

(One display level is missing in the Radio 868 MHz-Versions)

- Cumulated heat and cooling energy consumption since the last set day
- Segment test
- Actual heat and cooling output
- Actual flow rate
- Actual flow temperature
- Actual return temperature
- Actual temperature differential
- Meter's number of operating hours since it was first installed
- Set day and set month
- Stored heat and cooling energy consumption of previous year
- Stored heat and cooling energy consumption of the last 13 months **(is missing in the Radio 868 MHz-Versions)**
- Verification code
- Cumulated heat and cooling energy consumption since the meter was first installed
- Indication of faults (also refer to section below)

The units displayed are °C or K, kWh (or GJ on request), m³/h, kW, and hours.

Standard display is the cumulated heat consumption.

Fault messages

The meter monitors itself and can display faults it has detected. It differentiates between two categories of faults:

- Temporary faults: they have no impact on the correct functioning of the meter.
- Severe functional faults: the measurements have been stopped. In that case, the display alternates between error code and date the fault occurred for the first time. The values that have been cumulated until the fault first occurred remain stored.

Mechanical design

The heat and cooling meter is comprised of flow measuring section, electronic unit and two temperature sensors. The flow measuring section is mounted in the piping with the help of fittings. It is made of nickel-plated brass and contains the measuring chamber with the single-jet impeller. The inlet has a strainer to retain larger dirt particles.

The meter is supplied as a compact all-in-one unit, but the electronic unit can be detached if required (split version).

Electronic unit

The electronic unit houses the electronics and the eight-digit LCD. The operating voltage of DC 3 V is supplied by a lithium battery. Below the display, there is a button for advancing the display.

The electronic unit on the flow measuring section can be swiveled through 270° and tilted by 90°.

Temperature sensors

The temperature sensors are immersion type sensors.

They are immersed either indirectly or directly. The temperature sensors consist of an immersion rod the end of which carries the sensing element (Pt500), the threaded nipple, and the shielded silicon cable which establishes the connection to the electronic unit.

The temperature sensors are designed for fitting in ball valves (direct immersion) or protection pockets (indirect immersion).

The sensors used are ready mounted, approved, mounted as pairs, and certified.

Sizing

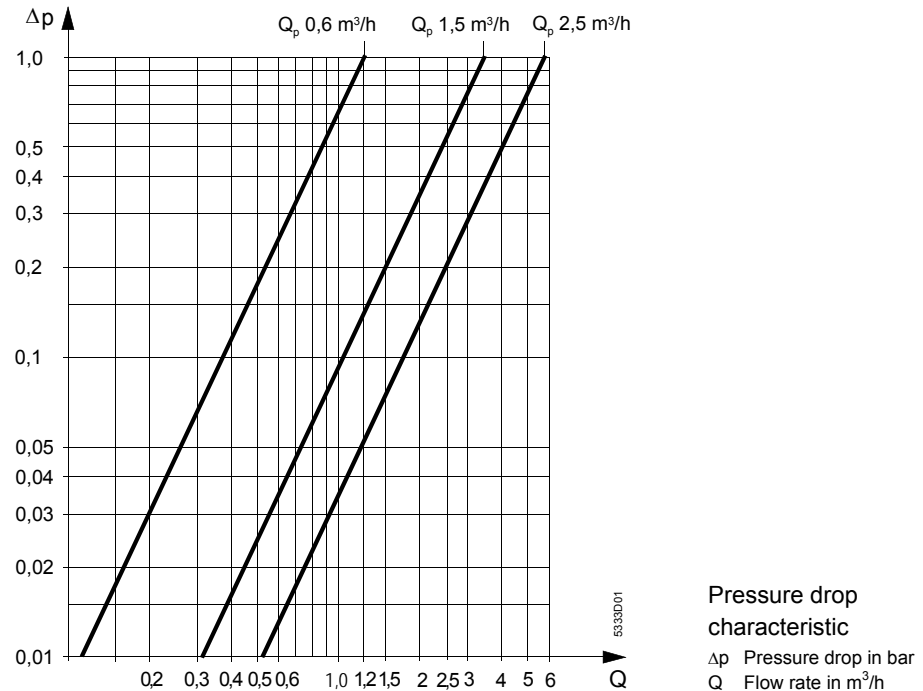

Mounting notes

- The local regulations for the use of heat and cooling meters (mounting, sealing, operation, etc.) must be complied with
- The heat and cooling meter must be mounted in the return pipe between two shutoff valves. To facilitate readout and service work, it should be easily accessible
- A settling path is required just upstream of the meter:
 - 150 mm with the mounting lengths of 80 mm and 110 mm
 - 200 mm with the mounting length of 130 mm
- If the meter is only used at the time of commissioning, it is possible to fit the spacer first
- Prior to mounting the meter, the piping must be thoroughly flushed; for this purpose, the spacer is required
- When mounting the meter, the direction of flow (indicated by an arrow on the body) must be observed
- If T-pieces of other manufacture are used, it must be ensured that they are compliant with EN 1434
- The electronic unit can be mounted away from the flow measuring section (split version). If the hole in the wall is too large for the unit, it can be mounted with the help of the mounting cover. If required, a chromium-plated covering plate can be used
- The electronic unit should be positioned such that it is easy to read
- After mounting, the required test pressure must be applied to the plant
- The electronic unit, the two temperature sensors and the fittings must be sealed to ensure protection against tampering.
If required, the M-bus service interface must also be sealed
- The piece of piping where the temperature sensors are located should be lagged

Operating notes

- For recalibration, the local regulations must be observed

Technical data

Measurement accuracy class	3 to EN 1434			
Environmental class	A to EN 1434			
Unit of energy				
Standard	KWh			
On request	GJ			
Max. heat output that can be measured	300 kW			
Flow rates	0.6 m ³ /h	1.5 m ³ /h	2.5 m ³ /h	
Min. flow rate q_i (Q_{\min}) H / V	6 / 12 l/h	15 / 30 l/h	25 / 50 l/h	
Nominal flow rate q_p (Q_{nenn})	600 l/h	1500 l/h	2500 l/h	
Max. flow rate q_s (Q_{\max})	1200 l/h	3000 l/h	5000 l/h	
Starting flow, horizontal	1.2 l/h	3 l/h	5 l/h	
Max. perm. operating pressure	16 bar			
Range of use of flow measuring section	1...90 °C			
Temperature measurement	Heating:		Cooling:	
Measurement range temp. sensors	20...110 °C		1...19,4 °C	
Temperature differential	3...90 K		from 0.6 K	
Output signal				
under measuring conditions	optional M-bus (EN 1434)			
in test mode	optional M-bus (EN 1434)			
	optional voltage pulses (DC 3 V)			
Behavior in the event of excessive flow				
flow rate = 2 q_s	Linear			
flow rate > 2 q_s	constant			
Perm. ambient temperature				
Transport und Storage	5...55 °C			
Operation	max. 55 °C			
Battery life	>10 years			
Connections and weight	0.6 m ³ /h	1.5 m ³ /h	1.5 m ³ /h	2.5 m ³ /h
Pipe connection (inlet and outlet)	¾"	¾"	¾"	1"
Mounting length	110 mm	80 mm	110 mm	130 mm
Weight	0.73 kg	0.65 kg	0.71 kg	0.8 kg
Temperature sensors				
Sensing element	Pt 500 Ω to EN 60751			
Connecting cable	1.5 bzw. 2.5 m			

Additional technical data (only for pulse output meters WFx24...)

Pulse output	open collector + protection resistor 2440 $\Omega \pm 10\%$
Polarity reversal	not possible
Pulse length	$\geq 100\text{ms}$
Pulse pause	$\geq 100\text{ms}$
Max. voltage	$< 30\text{ V}$
Current	$\leq 0.1\text{mA}$
Impedance to ground (water pipe)	10nF (50 V)
Pulse valency	1 kWh per pulse (cooling energy)
Advice:	The service tools (ACS210, AZS210 and ABS210) can not be used with the pulse output meter!

Dimensions

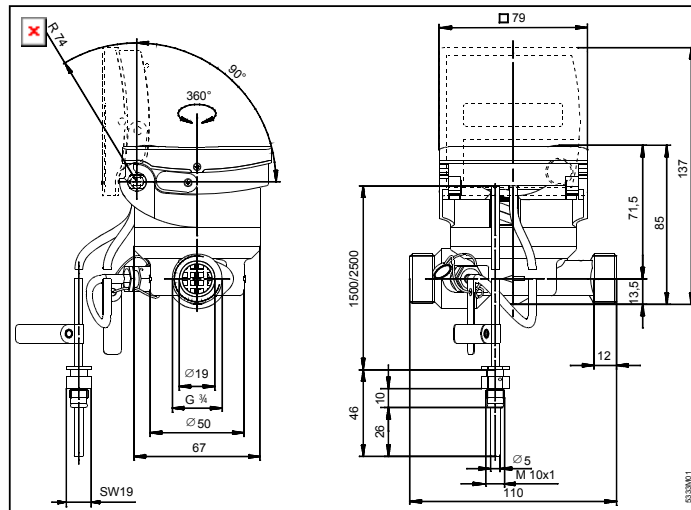

Mounting length 110 mm,
direct immersion of sensor

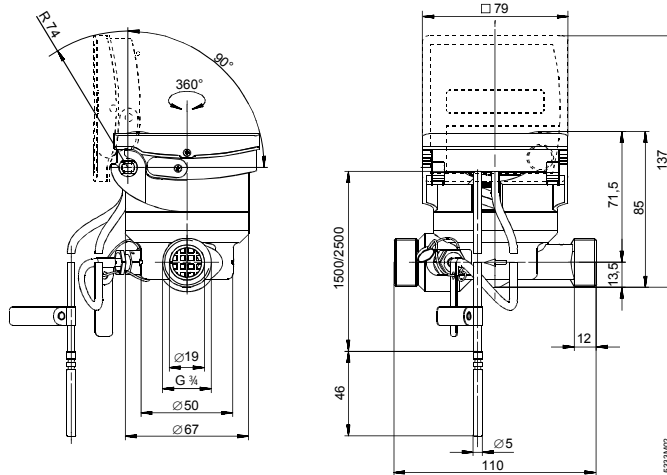

Mounting length 110 mm,
indirect immersion of sensor

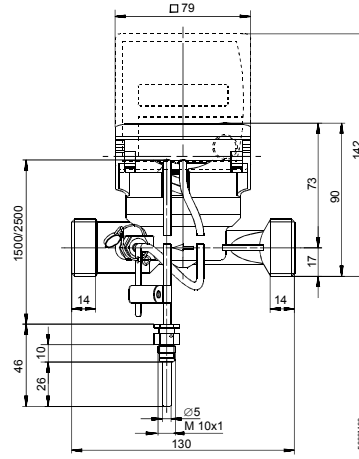
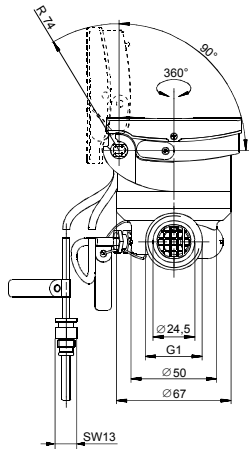

5333A03
Mounting length 130 mm,
direct immersion of sensor

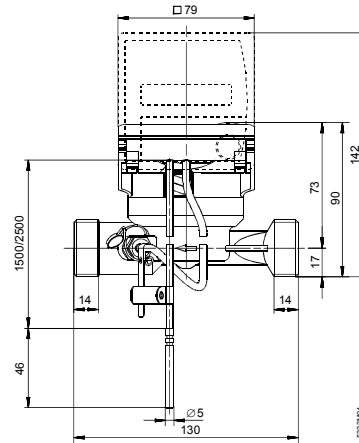
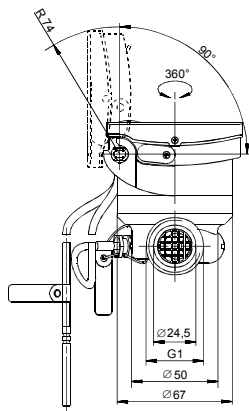

5333A04
Mounting length 130 mm,
indirect immersion of sensor

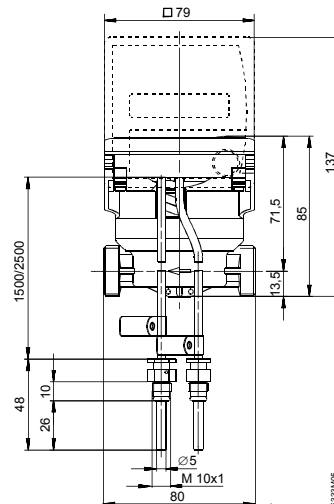
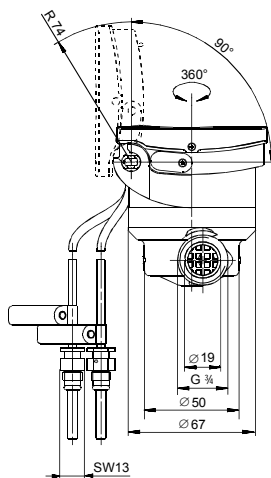

5333A05
Mounting length 80 mm, direct
immersion of sensors

This Data Sheet only contains general descriptions and technical features which, in the case of specific applications, may not necessarily apply, or which may change due to further development of the product. Technical details and features are binding only if explicitly agreed upon at the time of contract closure.

©2002 Siemens Building Technologies
Subject to alteration